

Bareback Tailstock Center Finder

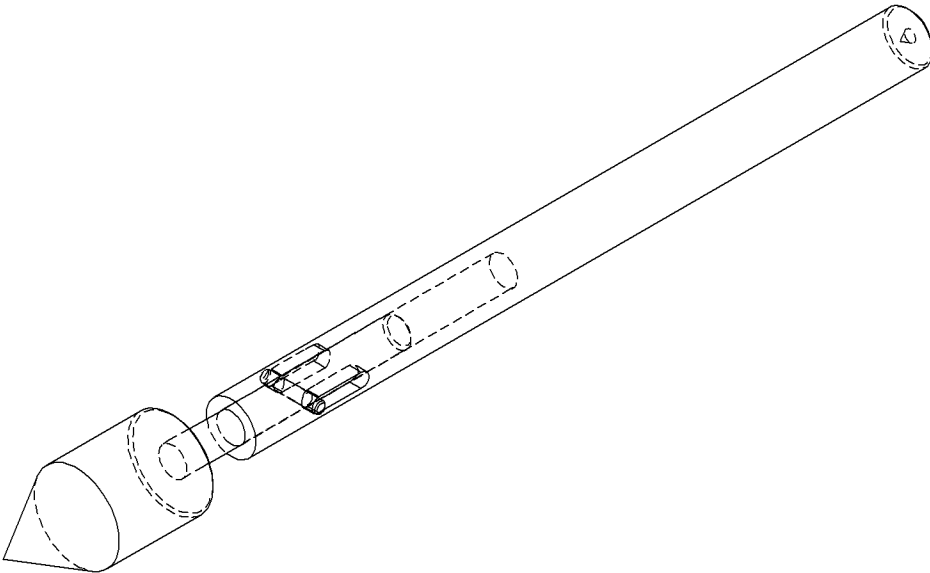

DIMENSIONS ARE IN INCHES
TOLERANCES (unless specified):
FRACTIONAL: $\pm 1/64$
TWO PLACE DECIMAL: $\pm .010$
THREE PLACE DECIMAL: $\pm .005$
ANGULAR: ± 1 deg

NOTE:

Copyright Damien Gendron 2005

Bareback Tailstock Center Finder	
DWG #	PAGE 1 OF 3

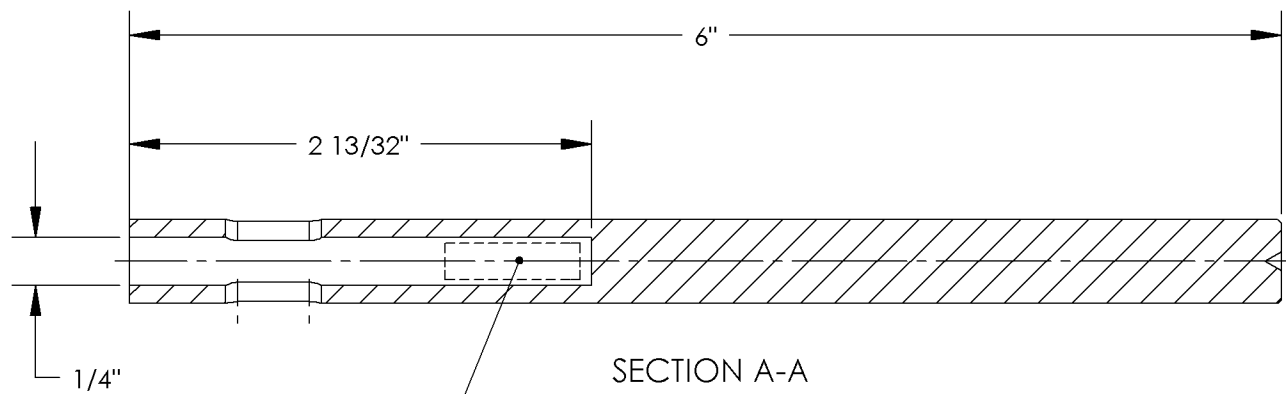
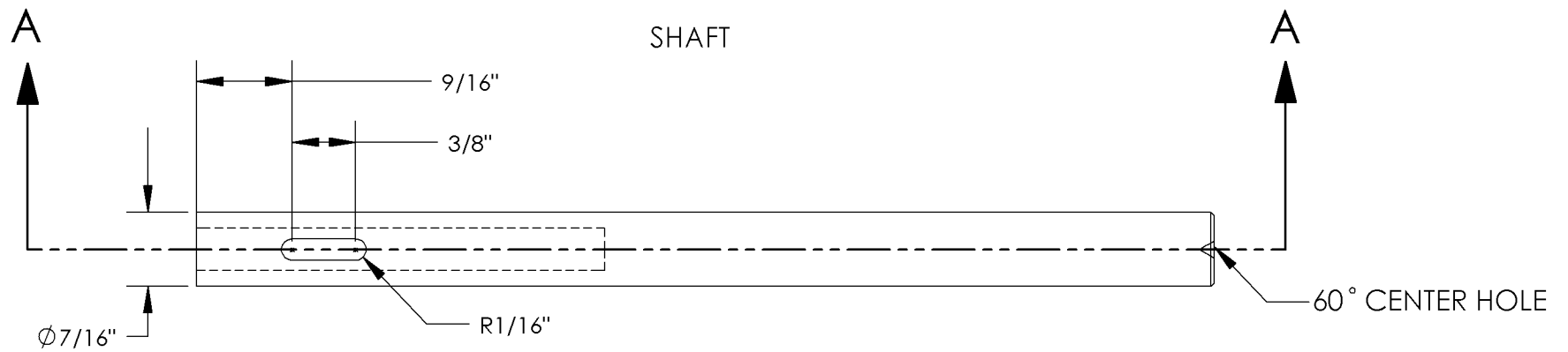

MATERIAL: MILD STEEL

DIMENSIONS ARE IN INCHES
 TOLERANCES (unless specified):
 FRACTIONAL: ±1/64
 TWO PLACE DECIMAL: ±.010
 THREE PLACE DECIMAL: ±.005
 ANGULAR: ±1 deg

NOTE:

Copyright Damien Gendron 2005

Bareback
 Tailstock Center Finder

DWG #

PAGE 2 OF 3

FOLLOWER

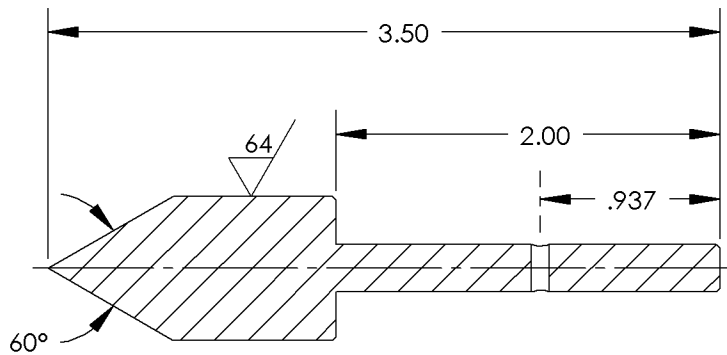
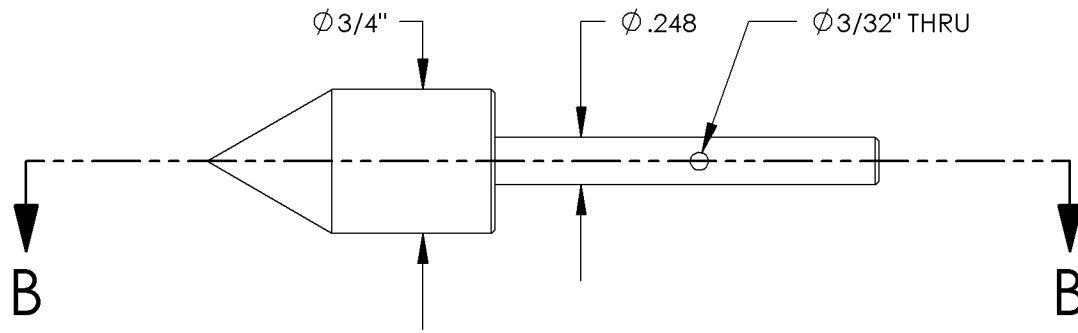

SECTION B-B

MATERIAL: TOOL STEEL (IDEALLY)

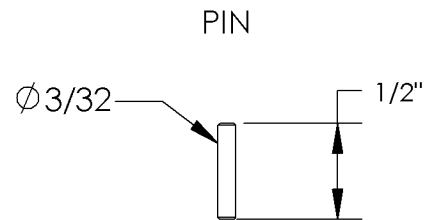

DIMENSIONS ARE IN INCHES
 TOLERANCES (unless specified):
 FRACTIONAL: $\pm 1/64$
 TWO PLACE DECIMAL: $\pm .010$
 THREE PLACE DECIMAL: $\pm .005$
 ANGULAR: ± 1 deg

NOTE:

Copyright Damien Gendron 2005

Bareback
 Tailstock Center Finder

DWG #